



Gyro Compass Equipment STANDARD 20 COMPACT

Option: Speed-error Correction

consisting of:

- Gyro Compass STANDARD 20, Type 110 - 800 or 110 - 806
- Distributor COMPACT, Type 110 - 224
- Repeater Compass, Type 133 - 555 or 133 - 556 (analog) or
Type 133 - 811 (digital)

OPERATOR MANUAL

Weitergabe sowie Vervielfältigung dieser Unterlage, Verwertung und Mitteilung ihres Inhaltes nicht gestattet, soweit nicht ausdrücklich zugestanden. Zuwiderhandlungen verpflichten zu Schadenersatz.

Toute communication ou reproduction de ce document, toute exploitation ou communication de son contenu sont interdites, sauf autorisation expresse. Tout manquement à cette règle est illicite et expose son auteur au versement de dommages et intérêts.

Copying of this document, and giving it to others and the use or communication of the contents thereof, are forbidden without express authority. Offenders are liable to the payment of damages.

Sin nuestra expresa autorización, queda terminantemente prohibida la reproducción total o parcial de este documento, así como su uso indebido y/o su exhibición o comunicación a terceros. De los infractores se exigirá el correspondiente resarcimiento de daños y perjuicios.



CONTENTS

Page

Safety Regulations

Declaration of Conformity acc. to EC Directive 96/98/EC

1	General	1
2	Notes on the Operating Instructions	3
3	Operating and Indicating Instruments on the Steering Repeater Compasses ...	4
4	Switching-on the Gyro Compass Equipment STANDARD 20 COMPACT	4
5	Signalling during Operation	5
5.1	Speed Error	6
6	Fault Operation	7
6.1	Warnings	7
6.2	Alarms	9
7	Switching off the Gyro Compass Equipment STANDARD 20 COMPACT	10

Safety Regulations



Caution!

- Maintenance and repair must be performed by trained and qualified personnel who are knowledgeable in equipment safety requirements!
- The gyro rotors only come to a standstill after a run-down time of approx. 15 - 30 min after the gyro compass has been switched off. During this time the gyro compass must not be opened for service or similar.
Gyrosphere might be damaged!

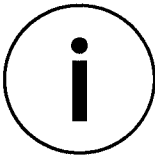

When an alarm occurs, the follow-up system in the gyro compass is switched off, the gyro compass does not supply any heading values, and all connected consumers no longer follow the heading change!

Immediately take the following measures:

- **Switch-over to redundant operating modes (other gyro compass, if possible; operation with magnetic compass)**
- **Contact Raytheon Marine Service.**
- If warnings occur, the function of the gyro compass equipment is not restricted. Elimination of the causes in good time prevents possible failures.
- The gyro compass equipment should not be switched off during times when the ship is in harbour for up to one week.

1

General

The gyro compass equipment STANDARD 20 COMPACT is used for navigation on board ships.

The gyro compass STANDARD 20 as a sensor ascertains true north independently from the earth's magnetic field and, thus, permits steering of a heading referred to geographical north. The heading signal from the absolute, digital position pick-off in the gyro compass STANDARD 20 undergoes an internal digital processing.

Option: Speed-error correction by the distributor COMPACT.

Built-in transmission systems ensure heading transmission to repeater compasses and further reference receivers.

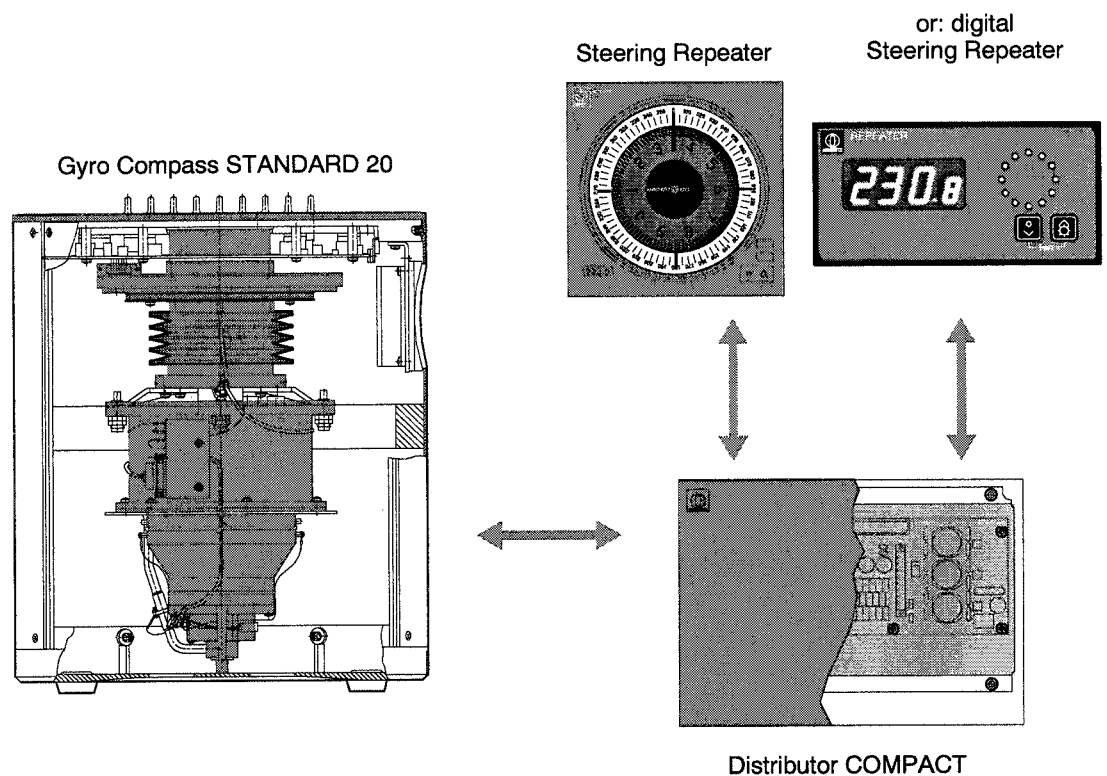

Fig. 1: Gyro Compass Equipment STANDARD 20 COMPACT

Operator Manual

This operator manual contains all operating instructions as well as a survey of possible warnings and alarms indicated on the digital display.

Service Manual

In addition to the operator manual a service manual is available. It contains informations about installation and first putting into operation

Gyro Compass Equipment STANDARD 20 COMPACT Operator Manual

The individual devices included in the system are used as follows:

- Gyro Compass STANDARD 20,
Type 110 – 800 or 110 – 806 (without casing for installation in the steering stand
ComPilot 20) (see also Description No. 110–800.DOC012)
 - Determination of "true north"
 - Indication of ship's heading – referred to "true north" – via a digital display
 - Transmission of the heading signals to the connected reference receivers via the distributor COMPACT

- Steering Repeater Compass, Type 133 – 555 or 133–556 (analog) or 133–811 (digital)
(see also Description No. 133–555.E03.DOC012 or 133–556.DOC012 or 133–811.DOC012)
 - Indication of the gyro compass heading, analog and digital
 - Digital display of errors and alarms within the complete system
STANDARD 20 COMPACT
 - Signalling of the operating condition of the complete system
 - Synchronization of the analog indication acc. to the digital display
(analog types only)

- Distributor COMPACT, Type 110 – 224
(see also Description No. 110–224.NG001.DOC012 or 110–224.SA001.DOC012)
 - Supply of gyro compass STANDARD 20 with the required voltages
 - Speed–error correction on the basis of the reference values supplied by the log and GPS (option)
 - Conversion of the information – serially received via the serial interface RS 422
HEADING SERIAL *) (heading, R.o.T.) – into signals for the steering repeater connected, or
 - Passing–on of the serial interface RS 422 Heading SERIAL *)
 - Fusing of the supply for connected loads (digital repeaters, steering repeater or
SPERRY step loads)

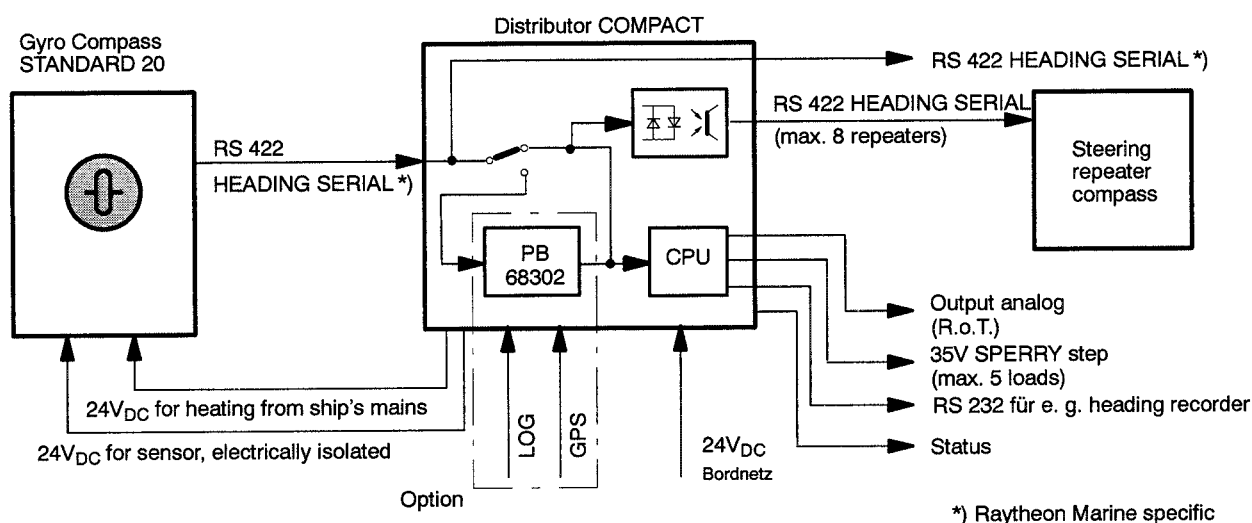

Fig. 2: Gyro Compass Equipment STANDARD 20 COMPACT -- Block Diagram

2 Notes on the Operating Instructions

The operation is interactive (action \Rightarrow reaction).

The operating procedure shown in the corresponding chapter is to be followed step by step. When necessary, helpful information in short form has been added to the figurative representation (symbols).

Explanation of symbols:



Key operation



Action, general



LED *out*



LED *on*



Audible signal *on*



Audible signal *out*

Gyro Compass Equipment STANDARD 20 COMPACT Operator Manual

3 Operating and Indicating Instruments on the Steering Repeater Compasses

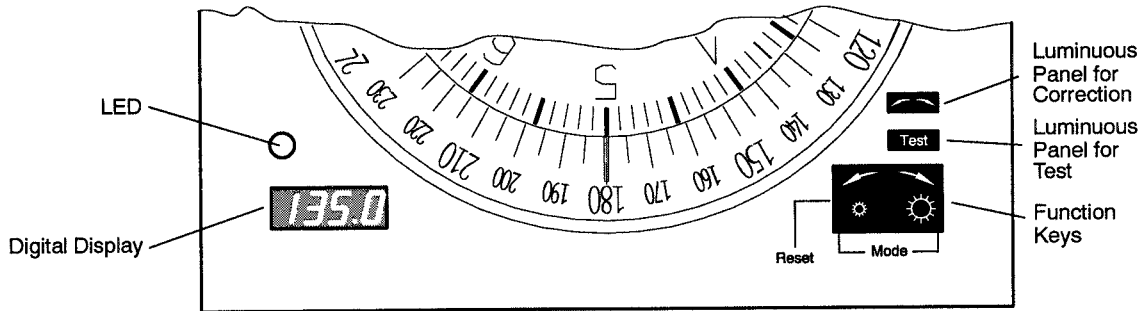

Fig. 3: Front Plate of the Repeater Compass, Type 133-555

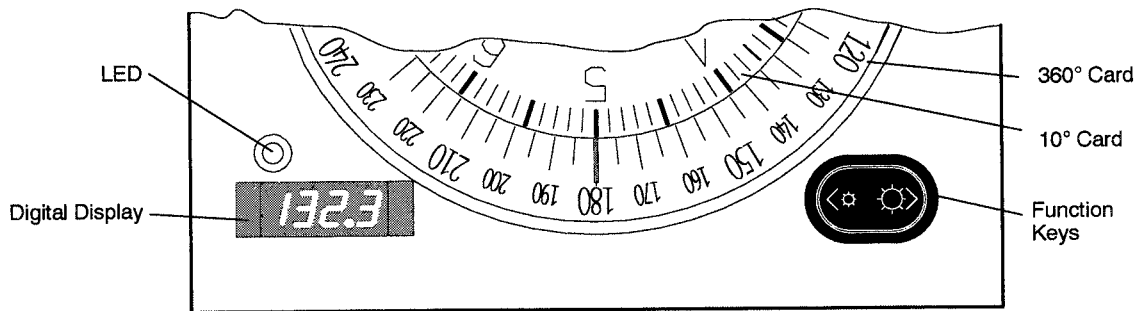

Fig. 4: Front Plate of the Repeater Compass, Type 133-556

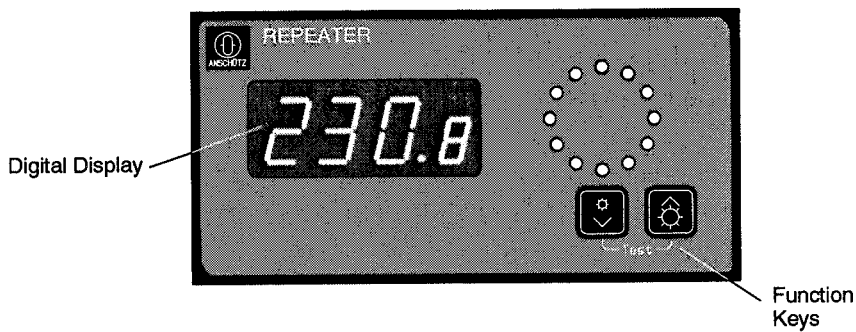

Fig. 5: Front Plate of the Repeater Compass, Type 133-811

4 Switching-on the Gyro Compass Equipment STANDARD 20 COMPACT











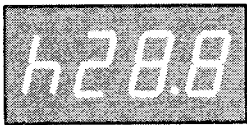

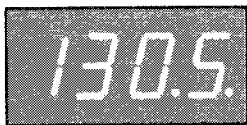

With switching on the 24 V supply voltage, the gyro compass equipment STANDARD 20 COMPACT is put into operation. The complete system is supplied via the distribution electronics.

Operation of the gyro compass equipment STANDARD 20 COMPACT is solely via the steering repeater compass.

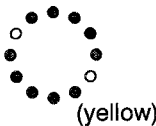
5

Signalling during Operation

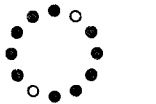
After the gyro compass has been switched on, the digital displays indicate:

Indications			Comments, Notes
Gyro Compass	Steering Repeater Analog	Steering Repeater Digital	
1 Heating Phase			
	 (yellow) 		During heating phase: Gyro compass: Indication of the supporting liquid temperature. For example: h : Heating phase 28.8 : 28.8 °C Repeater compasses: - Horizontal lines - LED lights up yellow
2 Settling Phase			
	 (yellow) 	  (yellow)	After reaching the lower operating temperature of 45 °C: Gyro compass: - Automatical switching-on of the internal follow-up system by the sensor electronics - During a settling time of approx. 3h, the digital display indicates the heading with a full stop behind the last position. Repeater compasses: - Heading indication - LED lights up yellow - triggered LEDs in the ring light up yellow <div style="border: 1px solid black; padding: 2px; display: inline-block;">Heading value still imprecise and not usable!</div>
3 Heading Indication			
	 (green) 	 	After termination of the settling procedure: Gyro compass: - Heading indication, with speed-error correction (option) uncorrected . Repeater compasses: - heading indication, with speed-error correction (option) corrected - LED lights up green - triggered LEDs in the ring light up green (Port) or red (STBD), resp. <div style="border: 1px solid black; border-radius: 50%; padding: 5px; display: inline-block; margin-top: 10px;">  Accuracy: After approx. 3 hrs.: better 25 After approx. 5 hrs.: better $0.15 \times 1 / \cos \text{latitude}$ </div>

5.1 **Speed Error**

The speed error is the difference between the heading indicated by the gyro compass and the true heading. The underlying causes of this error, which is governed by the ship's speed, heading and local latitude, are of the physical type.

This speed error must be corrected. The procedure of the correction computing with the appropriate tables can be found in the Operator Manual 'Gyro Compass STANDARD 20', Description no.: 110-800.DOC.012, Section 4.

Option:

When the reference value for speed (log) and latitude (GPS) are entered in the distributor COMPACT (Type 110-224 SA001), the speed error is corrected automatically; the distributor COMPACT then transmits a corrected heading signal to the peripheral units.

In case of failure of the log or GPS equipment, the speed error correction must be performed by computation (manually) (see above).



On the digital display of the gyro compass the **uncorrected** heading is indicated, whilst the **corrected** heading is indicated on the repeater compasses connected.

6 Fault Operation





6.1 Warnings

Warnings only occur on the gyro compass STANDARD 20.

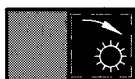

If warnings occur, the function of the gyro compass equipment is not restricted. Elimination of the causes in good time prevents possible failures.
(Refer to Section 6.2: 'Alarms').

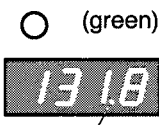
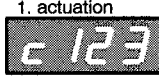
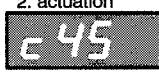
Warnings are indicated on the gyro compass and on the repeater compass with a code.

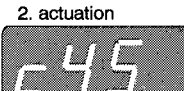







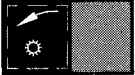

	Indications			Comments, Notes
	Gyro Compass	Steering Repeater Analog	Steering Repeater Digital	
1	Normal Warnings			
 or 	 Decimal point	 (green) Decimal point 1. actuation  2. actuation 	 Decimal point 1. actuation  2. actuation 	Gyro compass: The decimal point flashes for the duration of the warning. For additional procedures at the display of the gyro compass, refer to Service Manual 'Gyro Compass STANDARD 20' Description No. 110-800.DOC032, Section 2.3.1 Repeater compass: Decimal point is flashing. By pressing the right key, the pending type of warning is shown for as long as the key is pressed. This procedure should be performed twice.

The following warnings are displayed:

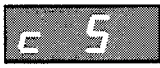
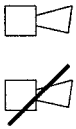

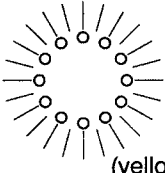

- c1: Fan, restricted function
- c2: Heating, restricted function
- c3: Temperature is >65 °C
- c4: Temperature controller, restricted function
- c5: Ship's mains interruption $t \geq 45$ °C (see point **2**)
- c6 *): Height of gyrosphere out of tolerance

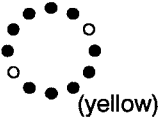
*) Valid from software version P02 E02.02

Gyro Compass Equipment STANDARD 20 COMPACT Operator Manual

	Indications			Comments, Notes
	Gyro Compass	Steering Repeater Analog	Steering Repeater Digital	
2 Ship's Mains Interruption with $\geq 45^\circ\text{C}$				
<div style="display: flex; align-items: center; justify-content: center;">  <div style="margin: 0 10px;">or</div>  </div>	<div style="text-align: center; margin-bottom: 10px;">  <p>Decimal point</p> </div> <div style="text-align: center;">  <p>Settling phase</p> </div>	<div style="text-align: center; margin-bottom: 10px;">  (yellow) </div> <div style="text-align: center; margin-bottom: 10px;">  </div> <div style="text-align: center; margin-bottom: 10px;">  </div> <div style="text-align: center; margin-bottom: 10px;">  (yellow) </div> <div style="text-align: center;">  </div>	<div style="text-align: center; margin-bottom: 10px;">  </div> <div style="text-align: center; margin-bottom: 10px;">  (yellow) </div> <div style="text-align: center; margin-bottom: 10px;">  </div> <div style="text-align: center;">  (yellow) </div>	<p>Gyro compass: As point 1. Then the digital display shows the settling phase.</p> <p>Repeater compasses:</p> <ul style="list-style-type: none"> - LED (LED ring) flashes yellow and cannot be dimmed. - 'c 5' suddenly appears - acoustic signal is heard (Analog types only) <p>Actuate left key:</p> <ul style="list-style-type: none"> - acoustic signal ceases (Analog types only) - LED shows continuous light (yellow) and can once again be dimmed. - triggered LEDs in the ring light up yellow and can once again be dimmed - Digital display shows the settling phase of the gyro compass.

For example:

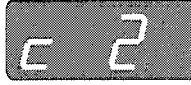
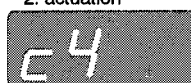
	Indications			Comments, Notes
	Gyro Compass	Steering Repeater Analog	Steering Repeater Digital	
	<div style="text-align: center;">  <p>Decimal point</p> </div>	<div style="text-align: center; margin-bottom: 10px;"> <p>1. actuation</p>  </div> <div style="text-align: center;"> <p>2. actuation</p>  </div>	<div style="text-align: center; margin-bottom: 10px;"> <p>1. actuation</p>  </div> <div style="text-align: center;"> <p>2. actuation</p>  </div>	<p>Repeater compasses: Heating and Temperature controller with restricted function.</p>

6.2

Alarms



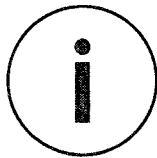





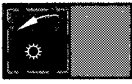

The alarms listed here are only on the gyro compass STANDARD 20 and are also displayed in coded form by the repeater compass! For own alarms on the repeater compass and the distributor COMPACT, please refer to the corresponding equipment manuals.

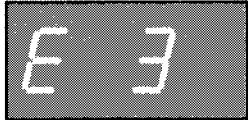

When an alarm occurs, the internal follow-up system in the gyro compass is switched off, the gyro compass does not supply any heading values, and all connected consumers no longer follow the heading change!

Immediately take the following measures:

- Switch-over to redundant operating modes (other gyro compass, if possible; operation with magnetic compass)
- Contact Raytheon Marine Service.

	Indications			Comments, Notes
	Gyro Compass	Steering Repeater Analog	Steering Repeater Digital	
 or 	for example: 	 (red)    for example:  (red) 	flashing  for example: 	Gyro compass: Error mode is indicated directly. See Service Manual 'Gyro Compass STANDARD 20' Description No.: 110-800.DOC032, Section 2.3.3 Repeater compass, analog type: - LED flashes red and cannot be dimmed - 'GYro' appears - acoustic signal is heard Press the left key: - acoustic signal ceases - LED shows continuous light (red) and can once again be dimmed - Digital display indicates the error mode. Repeater compass, digital type: 'GYro' appears flashing in the digital display. Press the left key: Digital display indicates the error mode.

Error modes:

- E1: Operating voltage in compass is faulty
- E2: Gyro supply faulty
- E3: Encoder faulty
- E4: Gyro current faulty
- E5: Gyro Compass internal Follow-up faulty
- E6: Temperature sensor breakdown
- E7: Height of gyrosphere outside of tolerance
- E8: Breakdown in heating
- E9: Overtemperature >70 °C

Gyro Compass Equipment STANDARD 20 COMPACT Operator Manual

7 **Switching off the Gyro Compass Equipment STANDARD 20 COMPACT**

The gyro compass equipment is switched off by switching off the 24 V power supply.

Note:



The gyro compass equipment STANDARD 20 COMPACT should not be switched off during times when the ship is in harbour for up to one week.

Gyro Compass Equipment STANDARD 20 COMPACT

NORMAL OPERATION

Switching-on Process

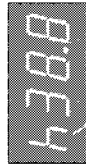
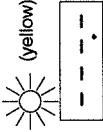
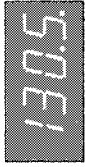
Switching-on of the Gyro Compass Equipment STANDARD 20 COMPACT on the main switchboard

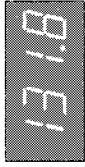
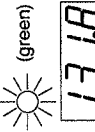
	Gyro compass	Steering repeater
- Indication of temperature of the supporting liquid during the heating phase		
- After reaching 45°C, the compass internal follow-up system is automatically switched on and course readings are still invalid. (luminous point after the last digit)		
- After a settling time of approx. 3 h, valid course readings with a restricted accuracy of $\leq 2^\circ$		

Dimming

- Press keys "☀" or "☀"



The brightness of card illumination and of the digital display vary directly:

- "☀" = darker
- "☀" = brighter

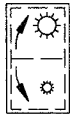
The brightness of lubber line illumination cannot be dimmed.

	Steering repeater
	

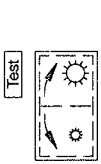
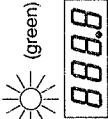
Test (digital display, luminous panels, buzzer)

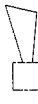
	Steering repeater
- Press keys "☀" and "☀" simultaneously (at least for 5s) until luminous panel of TEST lights up.	
After the keys have been released	
- the digital display indicates "888.8".	
- the audible signal sounds rhythmically.	
- the cards, keys, luminous panels, the 3-coloured LED and the digital display light up with maximum brightness.	
After automatic termination of the test (approx. 3s)	
- the digital display again indicates the current course value	
- the audible signal ceases	
- the brightness changes to the dimming level selected.	

Correction of Analog Indication (Cards)

Pre-condition:

No coincidence of between indicated card value and the digital display.

- Press keys "☀" and "☀" simultaneously (at least for 10s) until luminous panel of function CORRECTION lights up.
- By means of keys "☀" or "☀", adjust the cards for the digitally indicated value:
 - "☀" = lower
 - "☀" = higher
- 10s after the last setting, the function CORRECTION will automatically be left. The luminous panel is extinguished, the instantaneously adjusted course value is taken over.

Note:

If the keys "☀" and "☀" are pressed down for a period longer than approx. 15s, the service mode will be activated (LED flashing yellow). By pressing the RESET key, this mode will be left again.







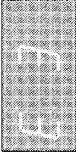

Gyro Compass Equipment STANDARD 20 COMPACT DISTURBED OPERATION

Signalling of Alarms with Errors in the Gyro Compass

After an error has occurred, the course information is switched off. The gyro compass then makes up to 4 attempts to switch on the course information again. After the fourth fruitless attempt, the course information remains switched off.

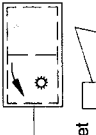
Effects: The connected course indications do no longer follow up the course changes.

Measures: Switch off the gyro compass equipment, and – by switching on again – perform re-start. After a fruitless attempt: Call the ANSCHÜTZ service!

	Gyro compass	Steering repeater	Further repeater compasses
On the gyro compass: Indication of error type up to 4 times in succession. On the steering repeater: Indication of Gyro, LED flashing red, audible signal is heard up to 4 times in succession	e.g.: 	 (red) Gyro 	 (red) - - - - Acknowledged state only
After actuating the RESET key (acknowledgement): - Indication of error type - Red LED shows continuous light - Audible signal ceases	 Reset  (red) E3	 (red) Gyro 	 (red) - - - - Acknowledged state only

Error types:



- E 1: Operating voltages in the compass are disturbed
- E 2: Gyro supply is disturbed
- E 3: Encoder is disturbed
- E 4: Gyro current is disturbed
- E 5: Compass internal Follow-up system is disturbed
- E 6: Temperature sensor failed
- E 7: Height of gyrosphere out of tolerance
- E 8: Heating failed
- E 9: Temperature > 70 °C

Signalling of Alarms with Errors in the Steering Repeater

Effects: The course indications of the steering repeater and of possibly further connected repeater compasses do no longer follow up the course changes.

Measures: Check connections or call the ANSCHÜTZ service!

- Indication of error type
- LED flashing red
- Audible signal sounds

 (red) SC1 	e.g.:  (red) SC1 Acknowledged state only
---	---

After actuation of the RESET key (acknowledgement):

- Red LED shows continuous light
- Audible signal ceases





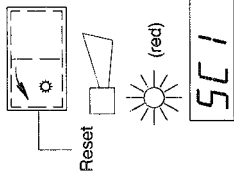

Error types:

- SC1: Serial interface defective or transferred telegram invalid
- Con: Data is missing or serial interface not connected



Signalling of Warnings in Case of Unusual Occurrences

If warnings occur, the function of the equipment is not restricted! Elimination of the causes in good time prevents possible failures (see handbook).

	Gyro compass	Steering repeater
Decimal point on both digital displays is flashing. During the following key actuation, the pending type of warning is indicated:		 (green) 13.18
Steering repeater: - Press key "R" twice	 1 st depression	
Gyro compass: - Press key on the sensor PCB twice (see handbook)	 2 nd depression	 c 123  c 45

Warning types:

- c 1: Fan, restricted function
- c 2: Heating, restricted function
- c 3: Temperature > 65 °C
- c 4: Temperature controller, restricted function
- c 5: Ship's mains interruption with $t \geq 45$ °C
- c 6: Height of gyrosphere outside of tolerance

Example: Heating and temperature controller, restricted function

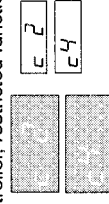

On the steering repeater, the ship's mains interruption is separately represented:

LED flashing yellow, digital display indicates c 5, audible signal sounds

- Press RESET key
- Audible signal ceases, digital display and LED show the settling phase of the gyro compass (see switching-on process)

